

NT-einteilig, einflügelig

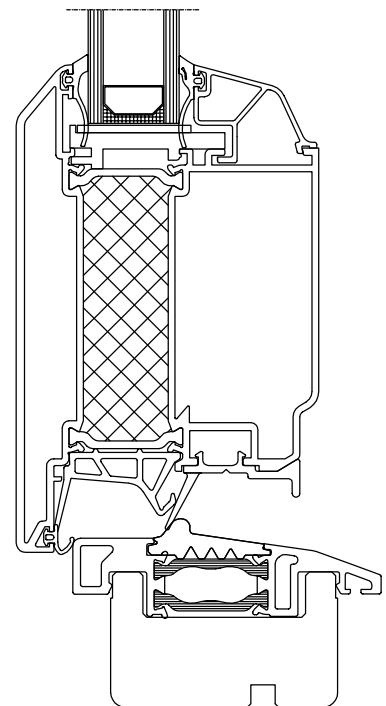

System außenaufgehend

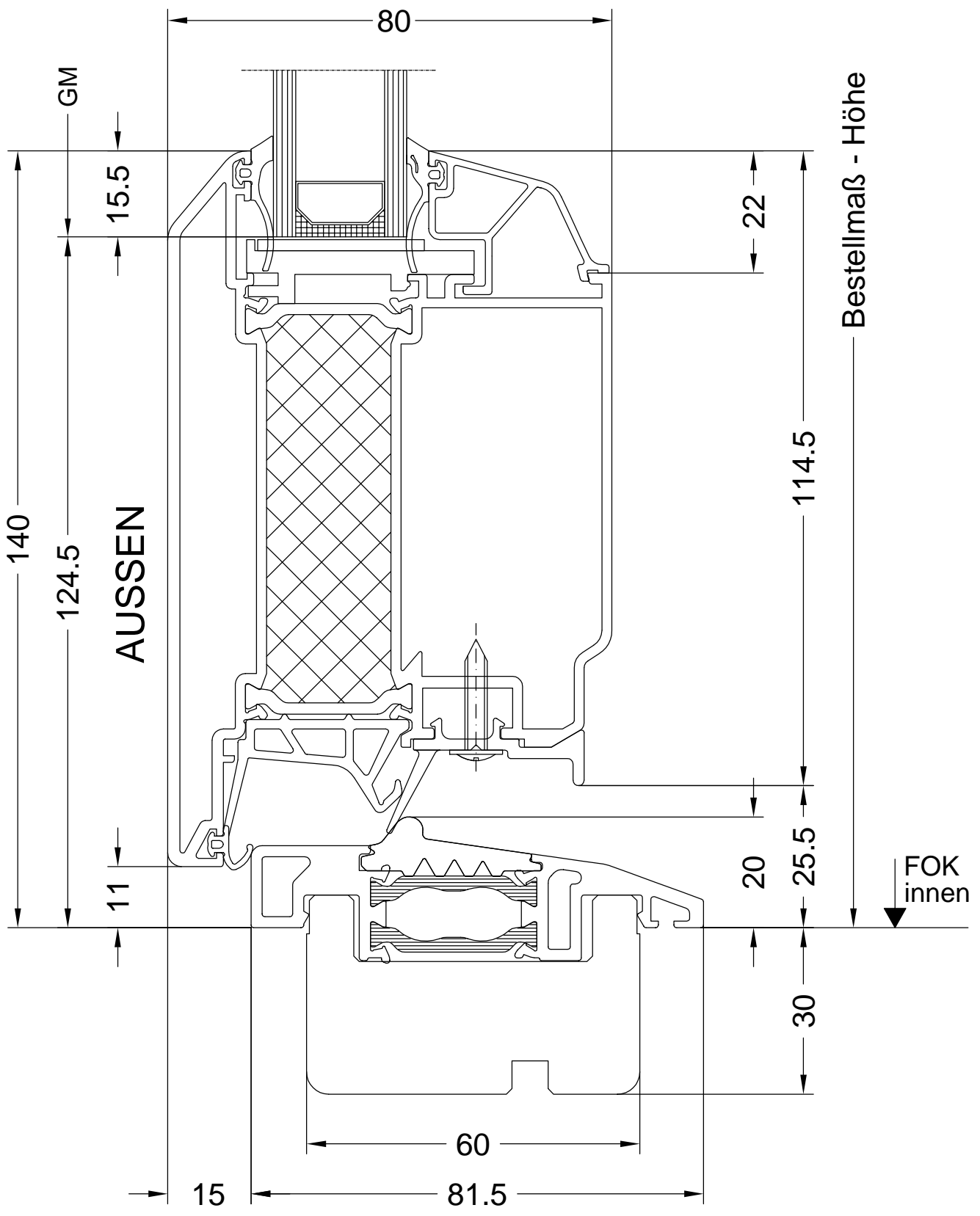

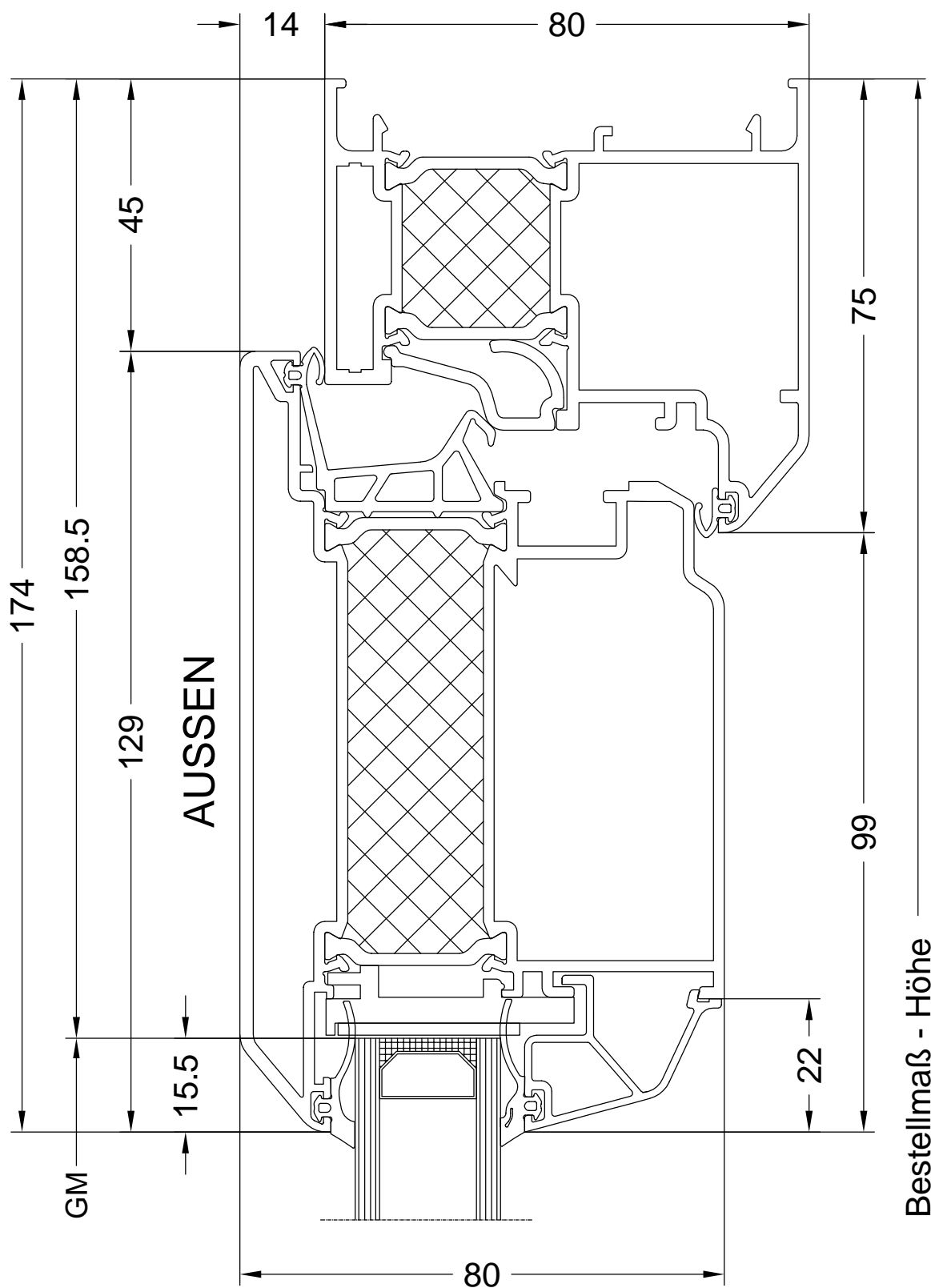

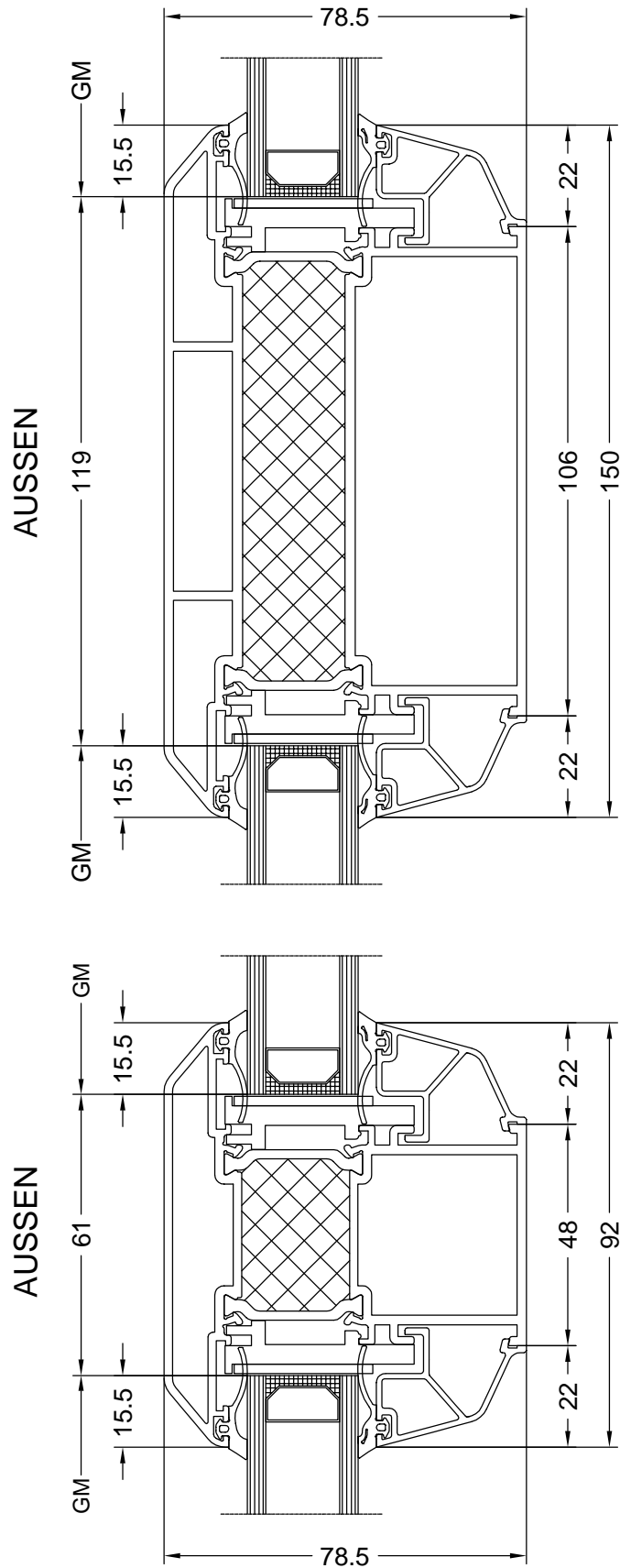

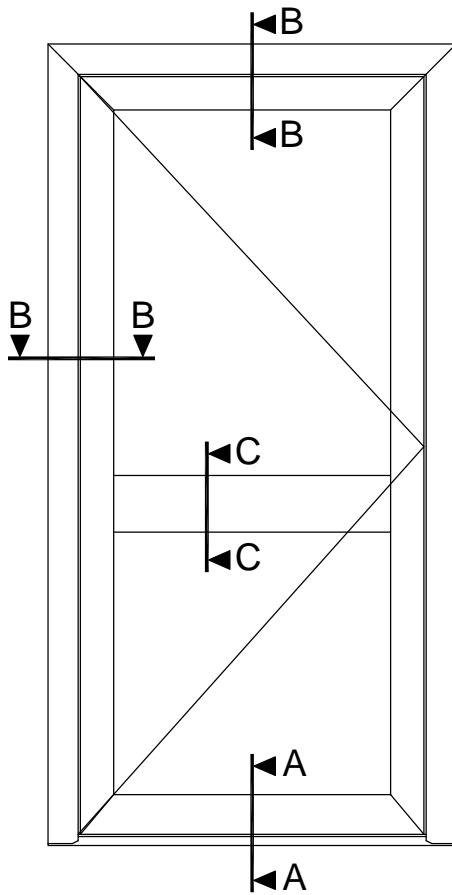

NT-einteilig, einflügelig

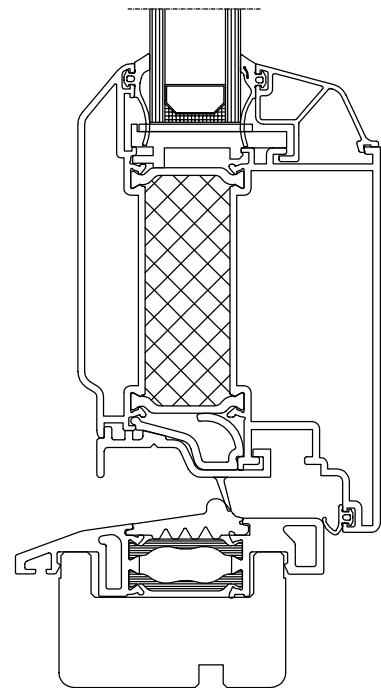

System innenaufgehend



